



SP[®]2P

Powered Speaker System

Product Specifications





FCC/ICES Compliancy Statement

This device complies with Part 15 of the FCC rules and Industry Canada license-exempt RSS Standard(s). Operation is subject to the following two conditions: (1) this device may not cause harmful interference, and (2) this device must accept any interference received, that may cause undesired operation.

Le présent appareil est conforme aux CNR d'Industrie Canada applicables aux appareils radio exempts de licence. L'exploitation est autorisée aux deux conditions suivantes: (1) l'appareil ne doit pas produire de brouillage, et (2) l'utilisateur de l'appareil doit accepter tout brouillage radioélectrique subi, même si le brouillage est susceptible d'en compromettre le fonctionnement.

Warning: Changes or modifications to the equipment not approved by Peavey Electronics Corp. can void the user's authority to use the equipment.

Note – This equipment has been tested and found to comply with the limits for a Class B digital device, pursuant to Part 15 of the FCC Rules. These limits are designed to provide reasonable protection against harmful interference in a residential installation. This equipment generates, uses, and can radiate radio frequency energy and, if not installed and used in accordance with the instructions, may cause harmful interference to radio communications. However, there is no guarantee that interference will not occur in a particular installation. If this equipment does cause harmful interference to radio or television reception, which can be determined by turning the equipment off and on, the user is encouraged to try and correct the interference by one or more of the following measures.

- Reorient or relocate the receiving antenna.
- Increase the separation between the equipment and receiver.
- Connect the equipment into an outlet on a circuit different from that to which the receiver is connected.
- Consult the dealer or an experienced radio/TV technician for help.

Caution

The equipment complies with FCC radiation exposure limits set forth for an uncontrolled environment.



SP[®]2P

The Peavey[®] SP[®]2P is a powered, bi-amplified, two-way speaker system engineered to provide very high levels of performance in a compact powered loudspeaker. This two-way powered system is comprised of a 1000 W peak switching power amplifier driving a 15" Black Widow[®] BWX series woofer, now with a long throw voice coil. The 2" RX[™]22CT titanium diaphragm compression driver is driven by a 500 W peak switching power amplifier, and is coupled to a low coloration waveguide with a coverage pattern of 100° horizontal by 50° vertical.

The SP[®]2P is capable of up to 130 dB peak SPL. The enclosure is constructed of plywood augmented with internal braces, covered with a textured black painted finish. The shape is a modified-trapezoidal form, with a full-length coated perforated steel grille, to offer an attractive yet durable powered speaker system. A pair of four-way inset handles, one on each side, provide convenient transport and handling. The cabinet and grille are black.

Two independent mixed input channels each offer a balanced input to the preamp/EQ electronics, and a level control. Each channel has one combo female XLR and 1/4" TRS phone jack. It is switchable between mic-level and line-level sensitivity. Channel 2 has a 3.5 mm media jack added. A line out section has male XLR connectors. The Thru outputs allow linking of additional speaker systems, or feed of the signal to a powered subwoofer, etc.

The power amplifiers providing the bi-amplification are low-distortion switching units providing 1000 W peak available power into the nominal 4 ohm load of the woofer, and a 500 W peak available power into the nominal 8 ohm load of the tweeter. The power supply for both amps is a switch mode type for low weight and high efficiency. Both amplifiers feature our DDT[™] compression, which virtually eliminates audible power amplifier clipping. Cooling is via forced air circulation. A four-way handle on each side provides ease of transport, while multiple fly points are provided to allow overhead rigging.

The combination of the Black Widow[®] BWX woofer with the RX[™]22CT tweeter and DSP crossover and EQ provide a clarity and impact beyond conventional powered enclosures. The switching power amps and switch-mode power supply, along with the professional grade speaker components, provide this high level of technological sophistication at a very light weight, while at a very reasonable cost.

- * BI-AMPLIFIED POWERED SPEAKER SYSTEM
- * 1000 WATTS PEAK AVAILABLE WOOFER POWER, 500 WATTS PEAK AVAILABLE TWEETER POWER
- * BOTH POWER AMPS HAVE DDT COMPRESSION
- * 15" BLACK WIDOW[®] BWX WOOFER
- * PEAVEY RX[™]22CT COMPRESSION DRIVER TWEETER ON A QUADRATIC THROAT WAVEGUIDE
- * PEAK SPL UP TO 130 DB WITH MUSIC!
- * DSP BASED CROSSOVER, LIMITING AND EQ
- * EQ PRESETS AVAILABLE VIA ROTARY ENCODER PUSHBUTTON SELECT
- * 9-BAND EQ AND OTHER SYSTEM SETTINGS ACCESSED VIA ROTARY ENCODER PUSHBUTTON SELECT
- * DYNAMIC BASS BOOST FUNCTION
- * UP TO 150 MS OF ARCHITECTURAL DELAY
- * FAN COOLED FOR MAXIMUM RELIABILITY
- * TWO INDEPENDENT MIXED INPUT CHANNELS, WITH GAIN CONTROL AND MIC/LINE GAIN SWITCH
- * EACH CHANNEL FEATURES A COMBO JACK WITH 1/4" TRS & FEMALE XLR BALANCED INPUT

- * INPUT 2 HAS A 3.5 MM (1/8") STEREO MEDIA INPUT JACK
- * OUTPUT CONNECTORS ARE MALE XLR
- * FOUR-WAY INSET HANDLES ON EACH SIDE
- * FULL LENGTH PERFORATED STEEL GRILLE
- * RUGGED PLYWOOD ENCLOSURE, WITH BRACING AND DADO CONSTRUCTION
- * POLE MOUNT INCLUDED
- * REDUCED WEIGHT – ONLY 59 POUNDS!
- * MULTIPLE FLY POINTS

Applications

The Peavey® SP®2P has a variety of applications such as sound reinforcement, public address, side fill system, karaoke or musical playback.

A typical signal source for the line-level inputs of the Peavey SP®2P would be a sound reinforcement mixing console (mixer) or the output from a CD player, MP3 player or tape deck. A dynamic microphone can be connected directly and used as well.

Bottom Rear Panel

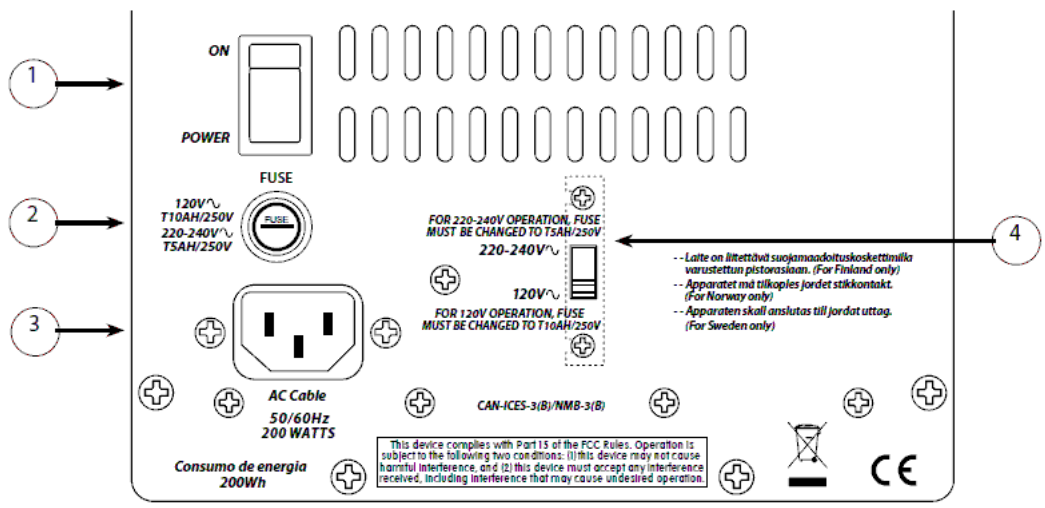

ON-OFF SWITCH (1)

This rocker switch supplies AC power to the SP®2P when switched to the ON position. The ON position is with the top side of the switch pushed “in” or nearly flush with the rear panel.

FUSE (2)



The unit is AC power line fuse protected from overloads and fault conditions with a slow-blow 5 x 20mm 250V fuse. This fuse is located within the cap of the fuse holder. If the fuse fails, **THE FUSE MUST BE REPLACED WITH THE SAME TYPE AND VALUE IN ORDER TO AVOID DAMAGE TO THE EQUIPMENT AND TO PREVENT VOIDING THE WARRANTY!**

The fuse in the SP®2P can be replaced with a time-delay type 5 x 20 mm size 250V rated fuse.

For 120VAC operation, a fuse rated at 10 amps should be used. In the USA, types GDC, GMC, 215, 218, and 477 cartridge-style 5 x 20 mm size fuses with a 10 amp 250V rating can be used.

For 220-240VAC operation, a fuse rated at 5 amps and 250V should be used, which conforms to the international fuse classification “T5AH”.

If the unit continues to blow replacement fuses, do not keep replacing them, it should be taken to a qualified service center for repair.

To replace the fuse, be sure to remove the IEC power cord from the IEC socket.

IEC POWER CORD CONNECTION (3)

This receptacle is for the IEC line cord (supplied) that provides AC power to the unit. It is very important that you ensure the SP®2P has the proper AC line voltage supplied. You can set the proper voltage for your SP®2P using the Voltage Selector switch (4) on the rear panel of the unit.

Please read this guide carefully to ensure your personal safety as well as the safety of your equipment. Never break off the ground pin on any equipment. It is provided for your safety. If the outlet used does not have a ground pin, a suitable grounding adapter should be used and the third wire should be grounded properly. To prevent the risk of shock or fire hazard, always be sure that the mixer and all other associated equipment are properly grounded.

VOLTAGE SELECTOR SWITCH (4)

The SP®2P has a voltage selector switch to allow switching between an input power voltage of 120VAC to a range from 220VAC to 240VAC, all at either 50 or 60 cycles per second (Hz). It should be set to the proper voltage for your country out of the box. However, world conditions are such that some areas have power line voltages differing from the voltage used by the majority of any given locale.

Be sure to check the position of the voltage selector switch to see that it matches the power line voltage used locally. If it does not match, then to change the voltage to the correct one, follow the steps outlined below.

Changing the Voltage Range of the SP®2P

First, make sure the SP®2P is disconnected from the power line, and that the power switch (1) is in the OFF position.

Second, unscrew the screws holding the clear switch protector on the voltage selector switch (4) just a little, just enough to allow rotation of the clear switch protector. The screws DO NOT need to be unscrewed very far.

Third, rotate the clear plastic protector about 90 degrees to uncover the voltage selector switch. One side of the cover has a slot, the other just a hole, the side with the hole is the side that pivots.

Fourth, using a small flat blade screwdriver, push the red selector switch slide plate to the other side from where it was. The voltage that is now visible on the red slide plate is the one you have selected.

Fifth, rotate the clear plastic protector back underneath the loosened screws, and tighten one down while holding the clear plastic protector in place. Tighten the other screw down, and make sure both screws are tight. If the screws are over-tightened, this could damage the voltage selector switch clear plastic cover, so do not apply excessive force to the screws!

Sixth, the fuse should be changed to the correct amperage rating. For an input power voltage of 120VAC, use a 10 amp rated, 250V 5 x 20 mm cartridge type time-delay fuse, which conforms to the international fuse classification “T10AH”.

For an input power voltage range of from 220VAC to 240VAC, use a 5 amp rated, 250V 5 x 20 mm cartridge type time-delay fuse, which conforms to the international fuse classification “T5AH”.

The IEC power cord that is correct for your locale can now be plugged into the IEC receptacle (3), and the Power switch (1) activated to turn on the powered SP®2P speaker system.

Top Rear Panel

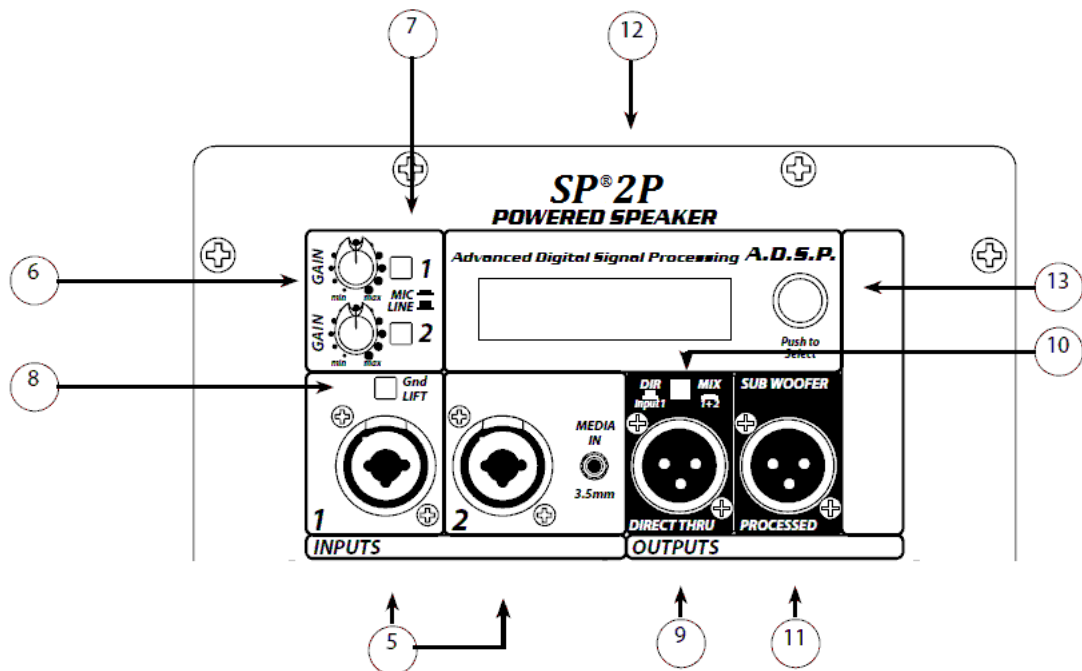

INPUTS (5)

Two input channels are provided. The line-level input is of the medium impedance balanced type. The jack is a combo female XLR and 1/4" TRS connector. Sensitivity of this input is 0.42 volts for full output, when the MIC/LINE switch (7) is in the LINE position.

Channel 2 has a 3.5 mm input jack for mobile device signal sources.

GAIN CONTROLS (6), Present on both input Ch 1 and input Ch 2

Controls the gain or output level of the same numbered input channel. It is used to directly set the system output level for a given input signal.

MIC/LINE switch (7), Present on both input Ch 1 and input Ch 2

Switches between LINE level gain (out position) and MIC level gain (in position). MIC position increases gain 26 dB to allow use of most dynamic microphones.

NOTE: Phantom power is not supplied on the INPUT (5) jacks

Gnd LIFT switch (8)

Allows the shield to be disconnected from the chassis ground to alleviate hum from ground loops

DIRECT THRU output jack (9)

This jack is intended for the use of linking multiple SP[®]2P's in a line, or to provide a feed to a powered subwoofer, or other electronics that needs to receive a full range version of the input signal.

DIR/MIX switch (10)

Switches between Direct Thru from channel 1 input, or a mix of channel 1 and channel 2 at the Direct Thru output (9)

SUB WOOFER PROCESSED output jack (11)

Provides a filtered signal for use with powered Sub woofer speaker systems other than the SP[®]118P or SP[®]218P. Follow the instructions in the Setup Wizard in the SP[®]2P menu on the LCD screen using the Push-To-Select button for proper subwoofer set-up and connection.

LCD Display (12)

Provides a menu read-out manipulated and activated by the Push-To-Select button (13)

Push-To-Select button (13)

Rotary knob that allow the user to select and choose menu options on the LCD display screen (12). Pushing the button in till it detents makes a menu choice, selecting the action or option highlighted in the LCD screen.

Safety Information

Cautions

The unit must be disconnected from the AC power source before any work is done on it. Refer all servicing to qualified service personnel.

 The back plate can become hot to the touch. Do not block or cover the fan or the exhaust louvers from ventilation. There must be a minimum of 4" of space behind the fan. Do not allow the airflow to become blocked by objects such as curtains or drapes, thermal building insulation, etc. It is recommended that the rear of the SP®2P not be placed in a closed space or a space that has no fresh, cool airflow.

Be sure to keep the microphone away from the front of the speaker after connecting it to the input, and while setting the microphone level, or very loud feedback will occur! Damage to the system is likely if this occurs!

DO NOT connect the inputs of the SP®2P to the output of a power amplifier. The inputs are meant to be driven from a line-level strength signal.

DO NOT remove the protective metal grille.

WARNING! The SP®2P is very efficient and powerful! This sound system can permanently damage hearing! Use extreme care setting the overall maximum loudness!

The apparent sound level of the SP®2P can be deceiving due to its clear, clean sound output. The lack of distortion or obvious distress can make the sound level seem much lower than it actually is. This system is capable of SPL in excess of 130 dB at 1 M from the speaker!

Flying/Rigging Information

 **Caution:** Before attempting to suspend this speaker, consult a certified structural engineer. Speaker can fall from improper suspension, resulting in serious injury and property damage. Do not suspend or mount any other product or device from this enclosure! Maximum enclosure angle 30°. Use only the correct mating hardware. All associated rigging is the responsibility of others.

Whenever possible, in addition to the nominal primary mounting method, use a suitable safety chain or wire rope, attached to one of the other groups of inserts, and firmly attached to a suitable structural member as indicated by a certified structural engineer.

We recommend the use of Thread-locker at the insert point bolts, so the bolts cannot vibrate loose.

Never transport the cabinet using the array bracket or other mounting brackets as a structural member, while the cabinet is mounted on an array bracket or other mounting bracket and unsupported otherwise, as this may unduly stress the mounting inserts. **DO NOT OVER TORQUE HARDWARE. ALWAYS USE SAFETY CHAIN. INSPECT RIGGING ANNUALLY.**

 This Peavey loudspeaker should be suspended overhead only in accordance with the procedures and limitations specified in the User's Manual and possible manual update notices. This system should be suspended with certified rigging hardware by an authorized rigging professional and in compliance with local, state and federal suspension ordinances.

 **WARNING!** (note to structural engineer)

NOTE: Use the correct type and grade of bolt into the mounting point inserts. The correct mounting bolt diameter and thread spacing are: M8, 1.25 mm per thread. Use of a metric grade 8.8 bolt or better is recommended.

Hardware for Flying/Rigging the SP®2P

Eyebolts or bracket bolts should be M8 metric thread, 1.25 mm per thread.

Eyebolts and bracket bolts must conform to certain minimum strength criteria for safety reasons.

Unspecified eyebolts found at local hardware stores are not strong enough to maintain safety for overhead flying or rigging. Use only forged steel shoulder machinery eyebolts designed for rigging use, which adhere to the stated standards as outlined below.

Hardware Specifications

Forged shoulder machinery eyebolts should be an M8 size, 1.25 mm per thread, and must conform to DIN 580 or ASTM A489, for Germany, BGV-C1 is the relevant standard. Minimum shank length should be 20 mm. The eyebolts should be rated for a minimum of 450 lbs straight pull working load

Bolts used on custom mounting brackets must be certified to be a metric grade 8.8 or better.

If there are any questions regarding the proper hardware or practices for safe flying or rigging of the Peavey SP®2P, contact a certified structural engineer, or consult with those local rigging companies who have trained and certified personnel.

Operation

Connecting AC Power To The SP®2P

The SP®2P comes with an 6-foot IEC connection AC power cord. If you are using an extension cord or power strip with this powered speaker, make sure it is of good quality and of a sufficient current capacity to maintain safety and maximize the power output capability of the SP®2P. For maximum undistorted output, do not connect any other device to the same extension cord that the SP®2P is connected to. Do not exceed the rated current capacity of the extension cord with the sum total of all units connected to it.

When first plugging in the AC cord, make sure the power switch is in the Off position, and then turn it On only once the power cord has been connected. Built-in muting will engage when the proper sequence of steps is taken.

Special Note for Permanent Installation

When installing the SP®2P, AC power runs will be used and a certified electrician should be consulted to be sure that all AC wiring complies with local codes and regulations. It is also advisable to use a cable clip properly affixed to the cabinet to strain relief the IEC power cord connected to the amplifier module at (3) so the power cord cannot be pulled out or vibrate loose.

Use of the SP®2P with a Speaker Stand

The SP®2P has a stand mount cup included so that the system can be stand mounted on a standard 1 3/8" (36mm) diameter stand pole.

When using stands or poles, be sure to follow these precautions:

- A. Check the stand or pole specs to make sure that it can support the weight of the SP®2P (59 lbs./26.8 kg), and observe all safety precautions stated by the stand manufacturer, including the maximum height the stand is rated for.
- B. Always place the stand on a flat, level and stable surface, and be sure to fully extend the stand legs as per the stand manufacturer's instructions.
- C. Try to make sure that the stand legs are oriented for the least danger of tripping to those in the vicinity of the stand. Never block a doorway or hallway with the legs of a stand.
- D. Try to route cables so that people will not trip over them, or tip the speaker over. Use of duct tape, cable channels or guards, or other appropriate tie-down/cover-up devices should be carefully considered and implemented.
- E. When installing or de-installing the speaker on the stand, it is a good practice to have a helper if possible, it can be hard to "thread the needle" and mate the stand cup to the stand pole while holding the SP®2P speaker system at arm's length. It is also helpful if someone holds the speaker stand and pole down while the SP®2P is removed from the stand pole, this prevents the SP®2P from pulling the pole up with it.
- F. When using stands outdoors, never attach banners or flags to the stands or the SP®2P speaker system, strong winds may cause the speaker to blow over. If there is a possibility of windy conditions, then it may be prudent to consider weighting or locking down the stand legs to prevent the SP®2P speaker system from being blown over.

Use of the SP®2P with an SP®118P Sub or an SP®218P Sub

The SP®118P Sub or SP®218P Sub can be used with a SP®2P using the threaded 1 3/8" diameter pole supplied with the Sub. All the precautions stated for use of the SP®2P with a speaker stand should be applied as appropriate to use of the SP®2P with a SP®118P Sub or SP®218P Sub. That would be primarily items B, D, E and F.

Connecting a Signal to the SP™2P

There are a variety of ways to input a signal to the SP®2P.

The inputs (5) provides either a balanced mic- or line-level input, allowing the use of a 1/4" TRS (ring-tip-sleeve) type phone plug or a male XLR plug.

There is also a 3.5 mm MEDIA IN jack on the Channel 2 input.

The 3.5mm TRS input jack has its own preamp designed for connection to the headphone jack on mobile audio devices. The Channel 2 Gain control adjusts the signal level from all of the channel 2 input connectors. It is possible to use both the combo mic or line input and the 3.5mm input by setting the channel 2 Gain control for the combo input source, and then using the mobile devices headphone volume to adjust its volume.

Note that the 3.5 mm jack mixes a stereo signal down to monophonic, as the SP®2P is a single sound source.

Do not connect cables to the jacks while the unit is ON and the Gain knob is turned up! While a standard single-ended 1/4" phone plug-equipped cable will work well and the balanced input circuitry will provide some interference rejection, a balanced cable using either the balanced TRS 1/4" phone plug or the XLR plug will provide superior interference rejection and performance.

Sometimes, with difficult interference problems, it will be helpful to lift the shield ground (Pin #1 of an XLR) of a balanced cable at the SP®2P end. Check any input changes carefully, always turning the Gain control down before plugging and unplugging cables, or lifting the ground.

Use of high quality, premium cables is recommended for the SP®2P, as these usually have better shielding and

materials and will provide greater long-term reliability. The best option is a shielded balanced cable no longer than necessary to reach the SP[®]2P. It is usually a good idea to leave some slack at the input to the SP[®]2P and also to tape the cables down or run them under a cable guard to avoid anyone tripping over them or pulling the SP[®]2P over when stand mounted.

Gain Control Adjustment

The SP[®]2P is equipped with Gain controls (6) on the input to facilitate use in many different applications. With the Gain control adjusted fully clockwise, gain is at maximum and the input sensitivity is 0.42 V RMS for full-rated output with the line level position of the Mic/Line switch (7). When driving the SP[®]2P from a mixer, it may be advantageous to reduce the input sensitivity by turning the Gain control to the halfway point. The SP[®]2P will now more closely match a typical power amp.

If the mixing board indicates clipping of its output signals, then all of the SP[®]2P power capability is not being utilized cleanly. Clipping the signal before it gets to the SP[®]2P is not optimal. Reduce the mixer output level and turn up the Gain control/s on the SP[®]2P.

The amplifiers in the SP[®]2P are equipped with DDT™ and there is an indication on the rear panel LCD display (12) that reads “DDT” whenever the DDT system engages.

If the sound seems heavily compressed, check this indicator; if it is blinking more than occasionally, then the drive level from the mixer (or the Gain control on the SP[™]2P) needs to be reduced.

When first turning on the sound system, switch on all upstream electronics first, then the SP[®]2P with its Gain control fully counterclockwise (all the way down). Begin checking levels with the mixer output level controls all the way down, and bring them up slowly with the SP[®]2P Gain control/s set to the desired setting (one-third way up recommended to start).

It is not good practice to turn the Gain control/s on the SP[®]2P all the way up and then try to control level only from the mixer, this approach would tend to pick up excess noise. Best practice would be to run a “hot” signal from the mixer down the cable to the SP[®]2P, and then turn the SP[®]2P Gain control up only as much as necessary to reach full desired output. With this approach, it is necessary to verify the mixer output is not clipping.

Disconnecting AC Power to the SP[™]2P

We recommend that the Power switch (1) be used to turn the unit off first, and then the AC power cord can be removed, this minimizes stress to the power amplifiers and the transducers from turn-off transients. The power switch has an arc suppression capacitor to help during turn-off, and tends to make a clean disconnect from the AC power, while the power cord IEC connector can make intermittent contact before finally becoming fully disconnected, e.g., as when wiggling the cord.

A two-line, 16-character per line LCD and a rotary push-to-select encoder make up the interface for this product.

The DSP processing control accessible by the user, consists of a 9-band graphic equalizer (GEQ), choice of output Polarity, selection of Bass Enhancement, and signal Delay. This is applied to the powered speaker system, and in some cases, to the processed output. The user can also select from a menu of preset Program EQ settings that are applied to the graphic equalizer and Bass Enhancer.

User interface:

Rotating the encoder takes the user thru the top level menu screens. These screens will display current information such as a Input Level meter, configuration and current user settings. Pressing the encoder on a top level screen will take the user to related selection screen(s) when relevant. The configuration screens play an important role in preparing the speakers for the intended application. The configuration screen comes up after the initialization screen when the speaker is powered on. If the configuration screen is not selected within 5 minutes the Input Level screen is displayed. The user can still select this screen at any time by rotating the edit knob. The configuration screens help the user set up the SP*2P system for optimal operation. By answering a couple of questions, the processor is configured and proper connections displayed. When complete, the user is returned to the main menu.

The LCD backlight will dim after 5-minutes without interface activity but returns to full brightness when the encoder is moved. When the backlight auto-dims, the display returns to the Input Level screen. This prevents inadvertent changes from occurring while reactivating the LCD backlight.

The main menu screens are:

- Configure?
- Input Level
- Program EQ (Presets)
- Bass Enhancement
- Delay
- Graphic EQ
- Polarity
- Power amp meters Low and High
- Power amp Temperature
- Front LED On/Off
- Auto power Off
- Security Lock

Main Screens:

Input Level meter: Displays current input signal level.

Will prominently display status if DDT is engaged, by displaying the letters “DDT” on the right hand side of the display.

Configure?

Push Select This is an overview display that is not directly edited.

Entering the configuration menu directs the user how to properly set up and connect the system.

First Screen displayed after pushing Configure?

Use Speaker with
Subwoofer? Yes or No

If subwoofer = No: then go to location screen
No is the default selection.

If subwoofer = Yes then: Subwoofer selection screen
Subwoofer used:
Selections
SP Subwoofer

Other Sub 100 Hz
Other Sub 110 Hz
Other Sub 120 Hz

NOTE: The rotary knob must be used to scroll down to see all the choices.

If SP Subwoofer
Connect Mixer to
Sub Input

Connect Sub Proc
Out to Input

Speaker Proc Out
is Muted

With the mixer output (sound source) connected to the subwoofer, all of the system adjustments will be made using the SP Sub DSP module. The User processing choices in the SP[®]2P, such as the 9 band GEQ, will be bypassed, the delay will be bypassed, and the processed output muted. Program EQ (presets), GEQ and delay screens are all affected. The hi-pass filter on the SP[®]2P woofer is unchanged from its full range setting, because the Sub performs the crossover functions.

If Other Subwoofer
Connect Mixer to
Speaker Input

Connect Proc
Out to Sub Input

When the Sub is selected, the program EQ (presets), GEQ and delay screens function normally. The Processed output sends a subwoofer signal out the processed output. The Hi-pass filter on the SP[®]2P woofer is raised to cross-over with the subwoofer processed output at the selected frequency.

Speaker Location: (configuration submenu)

This affects some of the dedicated processing of the woofer to account for boundary surfaces etc.

Pole Mount (Default Selection)

Flown

Floor Monitor

Program EQ: Displays current EQ selection (EDM preset is the default on 1st time power up)
(Presets) EDM, Voice, Rock, DJ...etc
The program EQ selection is applied to the Graphic Equalizer and Bass enhancer.
“Custom” is displayed if GEQ has been adjusted by the user.
The last preset used, including a Custom one, is what will load the next time the SP[®]2P is powered up.

Note: If input source is from the SP Sub High-Pass Processed output, then the screen will display:

“EQ Bypassed”
“Use EQ in SP Sub”

Bass enhancement: Off or On.

Delay: Current delay time
Adjust screen 0 to 150 msec also Feet and Meters
Note: In SP[®]2P if input source is SP Sub, then Display:
“Delay Bypassed”
“Set DLY in Sub”

Graphic EQ: Current settings 9 Bands +/- 12 dB at ISO octave centers (63Hz to 16 kHz)

Note: In SP[®]2P if input source is SP Sub, then Display:

“EQ Bypassed”
“Use EQ in SP Sub”

Press the encoder to enter the screen to adjust the GEQ. Turning the encoder selects the frequency band to be adjusted. Press the encoder to adjust that band. Pressing the encoder again returns to the band select mode. To exit to the main menu, turn the encoder past the 16 kHz band to the X and Exit will appear. Press the encoder to exit.

Speaker Polarity:
Normal (Default Selection)
Inverted

Power amp Level meter display:

The input signal to the two power amplifiers will be displayed in horizontal VU format. The Limit status of each channel is also displayed.

Temperature: The temperature of the amplifier is monitored and display as long as it is in a safe operating range. If the temperature gets too high, it goes into protect mode which is displayed here and on the main Input Level screen.

Front LED: Set LED operation to: On/DDT, Signal/DDT, or Off.
When On/DDT indication is selected, the LED is lit blue whenever the amplifiers are not shut down.
When Signal/DDT indication is selected, the LED is lit blue whenever there is an input signal present.
When Off indication is selected, the LED is not lit under any conditions.

Auto power off: Disable, 15, 30 or 60 minute delay.

Security Lock: A four digit security lock that can be engaged that will block editing of all parameters. If locked, entry of the access code will be required to allow temporary access for editing. It will automatically relock after 5 minutes of editing inactivity.

Troubleshooting

No Output at All

First, make sure the unit has AC power and is turned ON. Make sure the LCD on the power amp module is illuminated.

If not, make certain the ON/OFF switch (1) is in the ON position and check the IEC power cord connection (3) by ensuring it is fully engaged and seated. Make certain the AC line cord is plugged into a working AC outlet. Finally, check the fuse (2). (See the Rear Panel: FUSE section, for safety instructions.)

Once assured your unit is getting AC power, check that the SP[®]2P is getting a signal. Temporarily disconnect the cable running to its inputs and connect it to some other device capable of reproducing the signal (i.e., a power amp and speaker). If this produces a signal, make sure that all Level controls being used have been turned up to a satisfactory level (one-third to halfway).

If the SP[®]2P has been subjected to direct sunlight or excessive heat, the built-in thermal protection may have been triggered. If so, turn off the SP[®]2P and let it cool for a sufficient amount of time.

If there is still no output, contact your authorized Peavey dealer or the Peavey International Service Center.

Hum or Buzz

If the SP[®]2P is producing a hum or buzz, this can be AC outlet related. Try plugging the SP[®]2P into a different AC outlet. Sometimes, if a different circuit (breaker) is used for the mixer and for the SP[®]2P, it can cause hum problems. Unless it is not practical, it is best to use the same wall outlet (breaker) to supply power to both the mixer and the powered speaker.

Ensure that shielded cables have been used to route the signal to the SP[®]2P input. If speaker cables with 1/4" plugs are used as input cables instead of shielded cables, they will be prone to hum or buzz.

Hum may be ground loop related. It may be helpful to lift the shield ground (Pin #1) on a balanced cable at the SP[®]2P end. Check any input changes carefully by first turning down the Level control, before plugging and unplugging cables, or lifting the shield ground at the speaker end.

Check to make sure light dimmers are not on the same circuit as the SP[®]2P, the mixer or any source devices. If light dimmers are used, then it may be necessary to turn them full ON or full OFF to eliminate or reduce hum. This is a typical AC wiring/light dimmer interference problem, not a design flaw of the SP[®]2P.

The third wire (ground plug) on the AC plug should NEVER be removed or broken off, as this is a potential safety hazard.

Distorted or Fuzzy Sound

First, ensure the mixer (signal source) is not clipping or being overdriven. Make sure the Gain (6) control on the SP®2P has not been set too low. Check that the input plug is fully seated in the input jack on the rear panel of the SP®2P. Ensure that a power amp has not been plugged into the input jack of the SP®2P. If an extension cord is being used to provide the AC power to the unit, insure that it is of sufficient current capacity and that it is not also being used to supply power to any other device.

The SP®2P has built-in EQ to smooth and extend the natural response of the speakers. If excessive additional bass boost or HF boost have been added externally to the SP®2P, it could cause premature overload at high SPL. Reduce the amount of any external (mixer, rack) EQ and see if that clears up the distortion.

If no external bass boost or HF boost has been added, but there seems to be an excessive amount of bass boost (boominess, bass clipping, and/or treble boost (shrillness, sizzle, harshness), then you may have selected the wrong choice on the Set-Up Wizard in the DSP menu on the LCD display. Go back and select the proper choice,

If using the SP Sub as the main input from the mixer, and then running a cable from the Sub to the SP®2P, then the SP®2P should be set to USE WITH SP SUB on the Set-Up Wizard menu.

If the Set-Up Wizard menu choice seems to be correct, and there is still too much boost, then try a preset with less boost, such as the Acoustic (Flat) preset and make sure the Tone controls have not been set all the way up.

Finally, realize that even though the SP®2P is a powerful and high output unit, it does ultimately have limits, and it may need additional powered units (or a subwoofer) to provide enough sound output or coverage. In this case, try turning the mixer levels down a little to see if that clears things up. If, after checking all the things listed to check and anything else you can think of to check safely, and the system still exhibits problems, carefully note all conditions and check with your Peavey dealer for advice.

Care and Maintenance

Your SP®2P is a sturdy and durable product and will provide years of reliable use if properly cared for. Use common sense and read the safety warnings to avoid hazardous operating conditions.

The unit must be disconnected from the AC power source before any work is done on it. Refer all servicing to qualified service personnel.

Sunlight/Heat

Avoid prolonged exposure to direct sunlight, as this may cause the unit to overheat and thermally shut off.

Excessively hot operating conditions can also cause a thermal shutdown.

Do not store in extremely hot or cold conditions or extremely high humidity. Always allow unit to come to room temperature before use.

Cleaning

Never clean the SP®2P while plugged in or turned ON! When the unit has been fully disconnected from AC power sources, use a dry cloth to remove soil or other dirt. Never use strong solvents on the SP®2P, as they could damage the cabinet. Do not allow ANY fluids to drip inside the SP®2P.

Touch-Up

To touch up the painted surfaces of the SP®2P, you can use Peavey® Black Touch-Up paint (part # 00052110). Never paint the enclosure or other parts while the unit is plugged in or turned on!

Check for Secure Hardware

After the first few weeks of use and periodically thereafter, check the hardware of the SP[®]2P for tightness, including the rear panel screws and the screws that hold the baffle and rear cabinet together.

The unit is subject to a great deal of vibration, and this could cause the hardware to loosen with use.

Architectural and Engineering Specifications

The powered loudspeaker system shall have a frequency response from 57 Hz to 17 kHz. The peak SPL with inaudible distortion shall reach 130 dB with music as a source, when measured at a distance of 1M and driven to full output capacity. The system shall utilize a Peavey[®] 15" Black Widow[®] woofer and a RX22CT compression driver tweeter mounted on an asymmetrical Quadratic Throat CD horn. The nominal radiation pattern shall be 100° in the horizontal plane, and 50° in the vertical plane, with the vertical main polar lobe angled down 10 degrees with respect to straight ahead, the vertical coverage angles being +15. -35 deg.

The powered, bi-amplified loudspeaker system shall have two mixed input channels consisting of a medium impedance input connector consisting of one combo female XLR and 1/4" TRS phone jack on the rear panel.

Channel two shall have a 3.5 mm input jack as well.

There shall be a Direct Thru (output) connector consisting of a male XLR jack.

The output of this jack shall be switchable between just Ch. 1 input and a Mix of Ch 1 and Ch 2.

The system power amplifiers shall have an unfiltered frequency response of 20 Hz to 20 kHz which deviates no more than +1, -3 dB up to rated power, hum and noise better than 90 dB below rated power, and THD and IMD typically of less than 0.1%.

The woofer amplifier shall be capable of 500W continuous into a 4 ohm nominal load, and the tweeter amplifier shall be capable of 250 W continuous output into a 8 ohm load, and both shall incorporate independent signal compression.

The input signal shall be electronically divided into high frequencies and low frequencies by a Linkwitz-Riley fourth order slope line-level crossover at 1.8 kHz. The low frequencies shall be processed to provide bass boost, subsonic filtering and overall response shaping, and the high frequencies shall be equalized for response-shaping.

The enclosure shall be constructed of 15 mm plywood. Four-way inset handles shall be incorporated on each side. A full-length powder-coated metal grille shall be provided for horn and woofer protection. The cabinet shall incorporate a pole mount for speaker stand use, and four tall sturdy rubber feet for floor standing use.

The outside dimensions shall be: 26.53" (67.4 cm) tall x 16.75" (42.6 cm) wide x 16.93" (43.0 cm) deep, and the weight shall be 59 lbs. Power requirements shall be: 200 Watts nominal, 120 VAC, 50/60 Hz Domestic and 220-240 VAC, 50/60 Hz (Export). The loudspeaker system shall be called a Peavey[®] SP[®]2P.

Product Specifications

SPECIFICATIONS

Enclosure: Peavey® SP™2P

Frequency response: 57 Hz to 17 kHz

Low frequency limit (-3 dB point): 57 Hz

Usable low frequency limit (-10 dB point): 51 Hz

Internal power amplifiers (@120 VAC line):

Woofer - 1000 watts peak available power

Continuous Power: 500 watts @ less than 1% distortion

Tweeter - 500 watts peak available power

Continuous Power: 250 watts @ less than 1% distortion.

Nominal sensitivity (1W @1M, swept sine input in anechoic environment): 99 dB (average)

Maximum sound pressure level: 130 dB music peak

Nominal radiation angles: 100° horizontal by 50° vertical

The vertical main polar lobe is angled down 10 degrees with respect to straight ahead, the vertical coverage angles being +15. -35 deg.

Transducer complement: 15" Black Widow® woofer, Model 1508-4 SPS, and an RX22CT 50 mm voice coil, titanium diaphragm compression driver tweeter on an asymmetrical Quadratic Throat CD Horn.

Box tuning frequency (F_{box}): 60 Hz

Electroacoustic crossover frequency: 1.82 kHz

Crossover Slopes: 24 dB/octave (fourth order) low pass, 24dB/octave (fourth order) high pass, and driver EQ.

Input Connections: Two combo female XLR/ 1/4" phone jack providing balanced or unbalanced operation, and one 3.5 mm stereo media jack.

Output Connections: Two XLR Outputs, one Full Range Thru, electrically buffered with selectable option of Channel A input only, or Ch. A and Ch. B mixed. The other XLR output is a High-Pass Output

Controls: Ch. 1 and Ch. 2 Gain control knob. Ch. 1 and Ch. 2 Mic/Line gain select pushbutton

Status Indicators: Blue Illuminated LED on the front baffle indicates power On, illumination can be turned Off by user.

Rear panel LCD screen in Input Level mode, shows DDT activation by flashing "DDT" on the LCD screen, right hand side. Signal level indicated by bar graph coming from left hand side of LCD.

Electronic Crossover: DSP based, with LCD display and Rotary Encoder Knob for selection of EQ presets and Graphic EQ. Crossover Frequency Set to 2.0 kHz. Low Pass slope: 24 dB/octave, High Pass slope: 24 dB/octave

DSP Section Specifications:

Latency: Approx. 2.7 msec

Sampling frequency: 96 kHz

Bit Depth: 24 bits for ADC/DAC, 32 bits for DSP calculations.

Enclosure materials and finish:

Plywood with a textured black polyurethane finish. Full length black powder coated metal grille.

Mounting:

12) M8 Threaded Mounting Suspension Points (3 top, 3 bottom and 2 each side & 1 each top rear and bottom rear). Built-in stand-mount adapter and four large rubber feet on bottom for floor use

Dimensions:

H x W x D

26.53 in. x 16.75 in. x 16.93 in.

674 mm x 426 mm x 430 mm

Weight:

59 lbs. (26.8 kg)

ELECTRONICS AND AMPLIFIER SPECIFICATIONS:

Electronic input impedance (nominal):

Balanced inputs: 10 k ohms line level sensitivity selected.

Unbalanced input: 5 k ohms, line level sensitivity selected.

Mic switch sensitivity Increase: 26 dB

Infrasonic filter protection: 36 dB/octave roll-off

Nominal amplifier frequency response: +0, -1 dB from 10 Hz to 30 kHz

Hum and noise: Greater than 90 dB below rated power

DDT dynamic range: Greater than 14 dB

THD and IM: Typically less than 0.1 %

Damping factor: Greater than 50 @ 1000 Hz, 4 ohms

Power requirements of Peavey® SP®2P system (domestic):

Nominal 200 watts, 120 VAC, 60 Hz

Fuse Type

For 120 VAC USE: International fuse classification T10AH 250V. In the USA, types GDC, GMC, 215, 218, and 477 cartridge-style 5 x 20 mm size time-delay fuses with a 10 amp 250V rating can be used.

For 220-240VAC USE: International fuse classification T5AH 250V . This is a cartridge style 5 x 20 mm size time-delay fuse with a 5 amp 250V rating.

Specifications subject to change without notice.

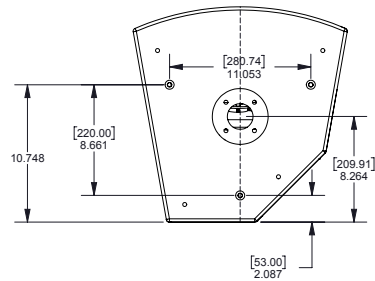
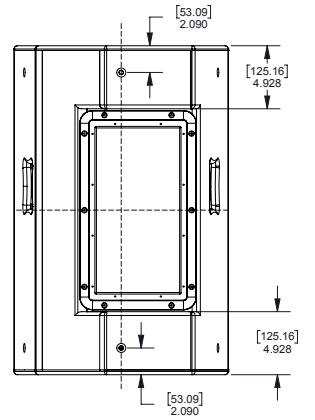
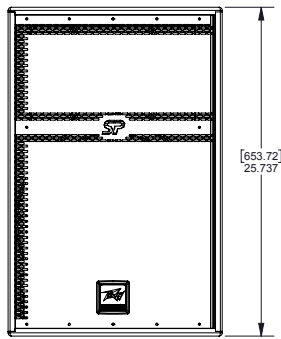
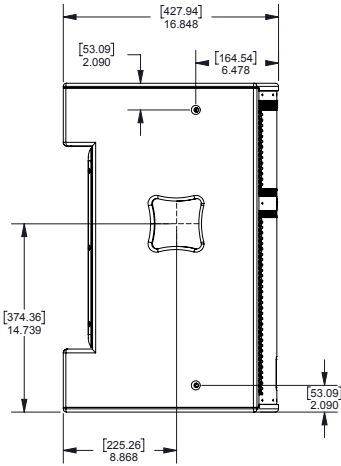
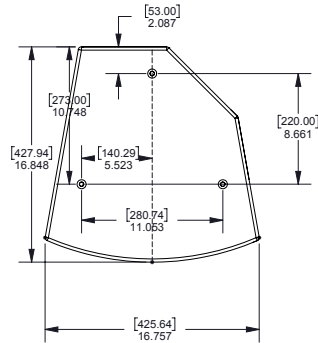



www.peavey.com

Warranty registration and information for U.S. customers available online at
www.peavey.com/warranty
or use the QR tag below



Features and specifications subject to change without notice.

Peavey Electronics Corporation 5022 Hartley Peavey Drive Meridian, MS 39305 (601) 483-5365 FAX (601) 486-1278



Logo referenced in Directive 2002/96/EC Annex IV
(OJ(L)37/38,13.02.03 and defined in EN 50419: 2005
The bar is the symbol for marking of new waste and
is applied only to equipment manufactured after
13 August 2005