



CPL™ 4L⁺
Passive Column Array
Loudspeaker System



Operating
Manual

Model Number or Name:

Date of Purchase:

Serial Number:

Dealer Name:

Crest Audio® CPL™ 4L⁺

The Crest Audio CPL 4L⁺ is a compact passive column array loudspeaker designed for high quality transmission of speech, music playback, and live performance reinforcement applications where space is at a premium.

The CPL 4L⁺ can be utilized for both permanent installations and portable live sound applications. Perfect for public address, monitoring and background audio reinforcement purposes typically required in houses of worship, clubs, bars/restaurants, retail outlets plus education and corporate meeting facilities or anywhere high quality discrete audio distribution is required.

The CPL 4L⁺ is equipped with four 3 inch full-range Neodymium speakers having a 0.75 inch voice coil. The directivity pattern of the loudspeaker is measured at 90° horizontal and 25° vertical providing a wide yet well controlled audio coverage. Impedance of the loudspeaker is 8 Ohms allowing for easy daisy chaining. Connectivity is made via either looping 4-pin twist-lock or 4-pin Euroblock connectors.

The CPL 4L⁺ enclosure is built from prime-grade 12 mm plywood that offers sturdy mechanical and low resonant electro-acoustic characteristics together with a heavy-duty steel grille backed with acoustic foam to ensure maximum protection of the internal components. The loudspeaker is equipped with a total of 7 threaded suspension points offering multiple mounting options for various applications. Available in durable black and white finish.

Features

- Compact passive column array loudspeaker
- Four 3" full-range Neodymium speakers, 0.75" voice coil
- Continuous power handling: 120 Watts
- Nominal impedance: 8 Ohms
- Coverage pattern (HxV): 90° x 25°
- Connectors: 2 x 4-pin twist-lock & 4-pin Euroblock
- 2+/- Loop Through
- 12 mm Plywood construction
- Sealed box system
- 7 x M8 suspension points (1 top, 1 bottom, 2 each side, 3 rear)
- Various mounting options
- Textured polyurea paint
- Available in Black and White

Configuration: Passive column array speaker

Power Handling*: 120 Watts Continuous, 240 Watts Program, 480 Watts Peak

*To reach the rated power, there must be an infrasonic filter set to 150 Hz, 12 dB / Octave Butterworth minimum filtering. If the CPL 4L⁺ is used with a crossover for a Subwoofer, then the high pass section needs to meet this criteria at a minimum. A higher frequency and/or filter slope is acceptable.

Nominal Impedance: 8 Ohms

Sensitivity (1W/1m): 93 dB

Maximum SPL (1m): 114 dB @ 120 Watts; 120 dB @ 480 Watts Peak

Frequency Response*: 206 Hz - 13 kHz, ± 3 dB

*1m on-axis, swept-sine in anechoic environment

Frequency Range*: 150 Hz - 20 kHz, -10 dB

*1m on-axis, swept-sine in anechoic environment

Box Tuning Frequency: 207 Hz

Nominal Coverage Pattern (-6 dB): 90° H x 25° V

LF Driver: 4 x 3" (76 mm) Full-range Speaker - Crest Audio FSN030.71

LF Driver Voice Coil: 0.75" (20 mm)

Input Connections: 2 x 4-pin twist-lock (NL-4 style) & 1 x 4-pin Euroblock

Input, Pin 1+ = (+) positive; Pin 1- = (-) negative / Loop Through, Pin 2+ = (+) positive; Pin 2- = (-) negative

Enclosure Material: 0.5" (12 mm) Plywood

Finish: Textured polyurea paint, available in Black & White

Black Finish: RAL: 9004 Signal Black (Pantone: Black 6)

White Finish: RAL: 9003 Signal White (Pantone: 705)

Front: Full-coverage perforated steel grille, backed with acoustically neutral foam

Mounting Provisions: Five (5) M8 suspension points (1 top, 1 bottom, 1 left, 1 right, and 1 rear) and additional set of two (2) M8 mounting points rear for optional wall-mount and pole mount adapters

Overall Dimensions (HWD):

Front - 17.52" x 4.72" x 4.98" (445 x 121 x 126.5 mm)

Rear - 17.52" x 3.11" x 4.98" (445 x 79 x 126.5 mm)

Net Weight: 6 lbs (2.7 kg)

CAUTION

Before attempting to suspend this speaker, consult with a certified structural engineer. Speaker can fall from improper suspension, resulting in serious injury and property damage. Do not suspend or mount any other product or device from this enclosure! Use only the correct mating hardware. All associated rigging is the responsibility of others. Maximum enclosure angle 30 degrees.

Whenever possible, in addition to the nominal primary mounting method, use a suitable safety chain or wire rope attached to one of the other groups of fly point inserts, and firmly attached to a suitable structural member as indicated by a certified structural engineer.

We recommend the use of thread-locker at the insert point bolts, so the bolts cannot vibrate loose. Never transport the cabinet using the array bracket or other mounting brackets as a structural member, while the cabinet is mounted on an array bracket or other mounting bracket and unsupported otherwise, as this may unduly stress the mounting inserts.

This Crest Audio loudspeaker should be suspended overhead only in accordance with the procedures and limitations specified in the User's Manual and possible manual update notices. This system should be suspended with certified rigging hardware by an authorized rigging professional and in compliance with local, provincial or national suspension ordinances.

INSTALLATION

A total of seven (7) M8 1.25 mm per thread threaded mounting suspension points (1 top, 1 bottom, 1 left, 1 right, and 3 rear) are provided. These are plugged with a hex key beveled head bolts.

Five mounting suspension points are for use with forged shoulder machinery eyebolts and should be an M8 size, 1.25 mm per thread, and must conform to at least DIN 580 or ASTM A489, or whatever local, provincial or national suspension ordinances or regulations may additionally require. Eyebolts must be used at a minimum as a pair, never use just one eyebolt to hang the speaker overhead.

An additional set of two (2) M8 threaded mounting suspension points are provided at the rear center below the Euroblock input cup of the cabinet for the optional wall-mount or pole mount adapters.

DO NOT SUSPEND OR MOUNT ANY OTHER PRODUCT OR DEVICE FROM THIS ENCLOSURE!

 Use only grade 8.8 hardware or better, or whatever local, provincial or national suspension ordinances or regulations may additionally be required.

WARNING

The CPL 4L⁺ passive column array loudspeaker system is very efficient and powerful! This sound system can permanently damage hearing! Use extreme care setting the overall maximum loudness!

The apparent sound level of the CPL 4L⁺ can be deceiving due to its clear, clean sound output. The lack of distortion or obvious distress can make the sound level seem much lower than it actually is. This system is capable of sound pressure levels (SPL) in excess of 120 dB at 1 meter from the speaker!

Installation methods for optional mounting accessories

Note: Wall Mount and Pole Mount Adapters are not included. These are optional accessories and need to be ordered separately.

Installation Method 1 - Pole Mount Adapter

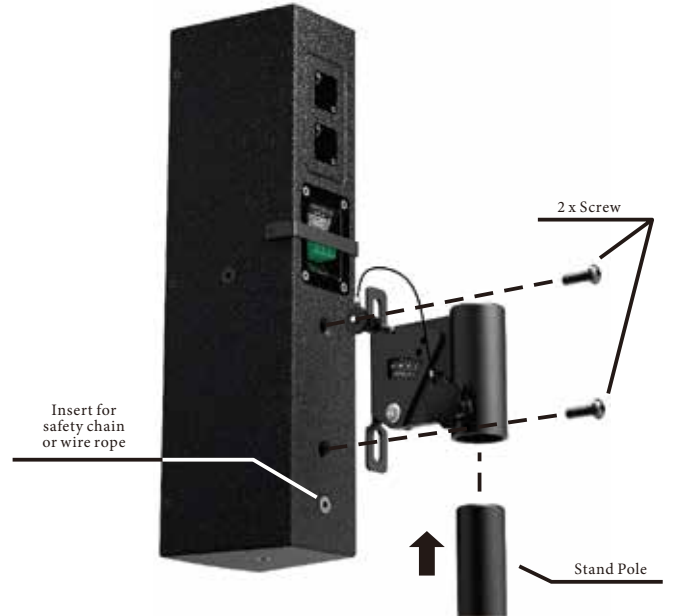

Installation Method 2 - Wall Mount Adapter

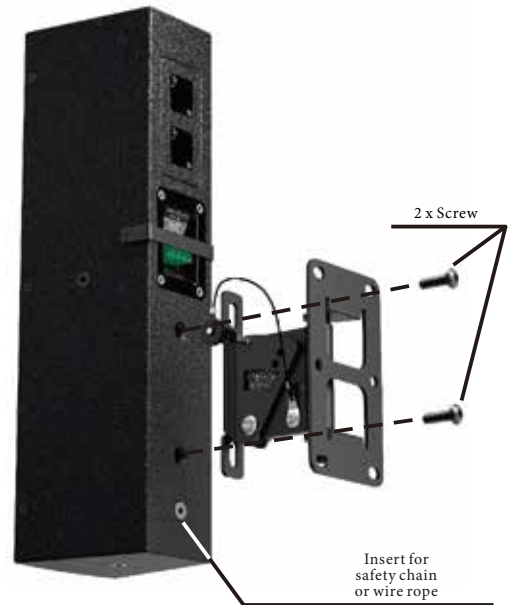

Wall Mount and Pole Mount Adapter Angle Adjustment

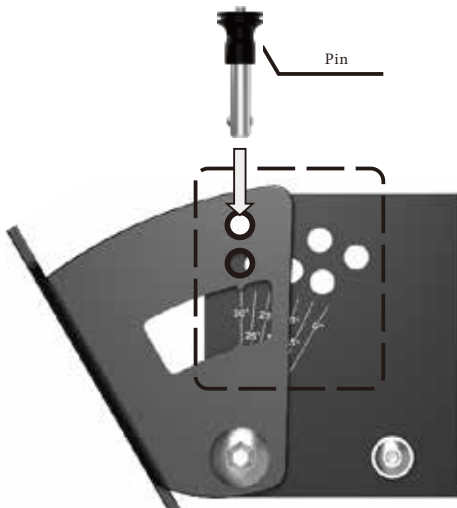

The angle adjustment range of the Wall Mount and Pole Mount Adapters is 0° to 30° in 5° steps.

Note:

When installing the adapters, the screws should be tightened in place. If necessary, use safety chain or wire rope inserts.

Grouping of insert sets for CPL 4L⁺**Group A**

One M8 insert on the top, designed to hang the cabinet using the proper eyebolt.

Group B

One M8 insert on the bottom, designed to hang the cabinet using the proper eyebolt.

Group C

One M8 insert on either side, designed to hang the cabinet using the proper eyebolt.

Group D

The M8 insert on the rear of the cabinet near the center bottom is for use as a pull-back or with a safety chain when using the other Groups A, B, and C, using the proper eyebolts.

Group E

A set of two M8 inserts on the rear, designed to be used with the optional Wall Mount or Pole Mount Adapters.

For Group A, B, C, and E, always use the inserts at a minimum as a pair; NEVER use just one insert to fly a cabinet! Group D can use just one for pull-back, or for safety wire/chain attachment, as long as there are two other eyebolts on a given cabinet wall used for primary suspension points.

For Group E, always use all two inserts of a given group as a set; NEVER use just one insert to fly a cabinet! The four insert groupings are meant to have all two inserts used at once within group E.

Specifications for insert mating hardware

Group A, B, C, and Group D should use an M8 forged steel shoulder-type lifting eyebolt, which meets the requirements of DIN 580 or ASTM A489, or whatever local, provincial or national suspension ordinances or regulations may additionally require. They should at a minimum be used in pairs for the primary suspension points, and in conjunction with a pull-back/aiming adjustment point insert, using M8 eyebolts of a similar specification. The length of the threaded shank on the eyebolts should not exceed 20 mm (approximately 3/4"), so that it does not engage the interior of the cabinet's sound absorbing lining. Thread pitch: 1.25 mm per thread.

Group E should use an M8, grade 8.8 or better, 1.0 mm per thread, metric bolt, that does not penetrate the cabinet past the cabinet surface more than 20 mm (approximately 3/4").

Notes on specific mounting methods using optional accessories**Mounting Method 1 - Wall Mount Adapter**

Instructions for use are included with the Wall Mount Adapter, and for permanent installation, once the angles have been finalized, use thread-locker on the two mounting bolts with lockwashers. The bolts for this method are Group E.

Mounting Method 2 - Pole Mount Adapter

This adapter allows use of the cabinet with a speaker stand (also referred to as a tripod stand) for temporary portable use. It is designed for use with a standard 1 3/8" (35 mm) diameter poles.

DO NOT TILT THE STAND/POLE TO TRY AND AIM THE CABINET VERTICALLY, THIS TYPE OF USE OF THE STAND POLE ADAPTER MOUNT IS NOT ALLOWED!

When using stands or poles, be sure to follow these precautions:

Check the stand or pole specs to make sure that it can support the weight of the CPL+ model, and observe all safety precautions stated by the stand manufacturer, including the maximum height and/or weight the stand is rated for.

Always place the stand on a flat, level and stable surface, and be sure to fully extend the stand legs as per the stand manufacturer's instructions.

Try to make sure that the stand legs are oriented for the least danger of tripping to those in the vicinity of the stand. Never block a doorway or hallway with the legs of a stand.

Try to route cables so that people will not trip over them, or tip the speaker over. Use of duct tape, cable channels or guards, or other appropriate tie-down/cover-up devices should be carefully considered and implemented.

When installing or de-installing the speaker on the stand, it is a good practice to have a helper if possible. It can be hard to “thread the needle” and mate the stand cup to the stand pole while holding the CPL+ speaker system at arm's length. It is also helpful if someone holds the speaker stand and pole down while the CPL+ speaker system is removed from the stand pole, this prevents the CPL+ speaker from pulling the pole up with it.

When using stands outdoors, never attach banners or flags to the stands or the CPL+ speaker system, strong winds may cause the speaker to blow over. If there is a possibility of windy conditions, then it may be prudent to consider weighting or locking down the stand legs to prevent the CPL+ speaker system from being blown over.

Use of the CPL+ Pole Mount Adapter with a subwoofer and associated pole:

Always be sure to place the subwoofer used in this manner on a flat, level and stable surface. Follow the manufacturer's instructions regarding how high the pole can be for a given size and weight of cabinet on top. Many of the precautions mentioned above for speaker stands will also apply to this type of use.

Installation Instructions for Euroblock Connector Retention Strap

Note: The retention strap is supplied with the system, only to be used as needed.

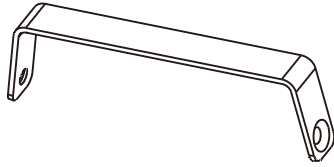

Euroblock Connector Retention Strap
(Included in the package)

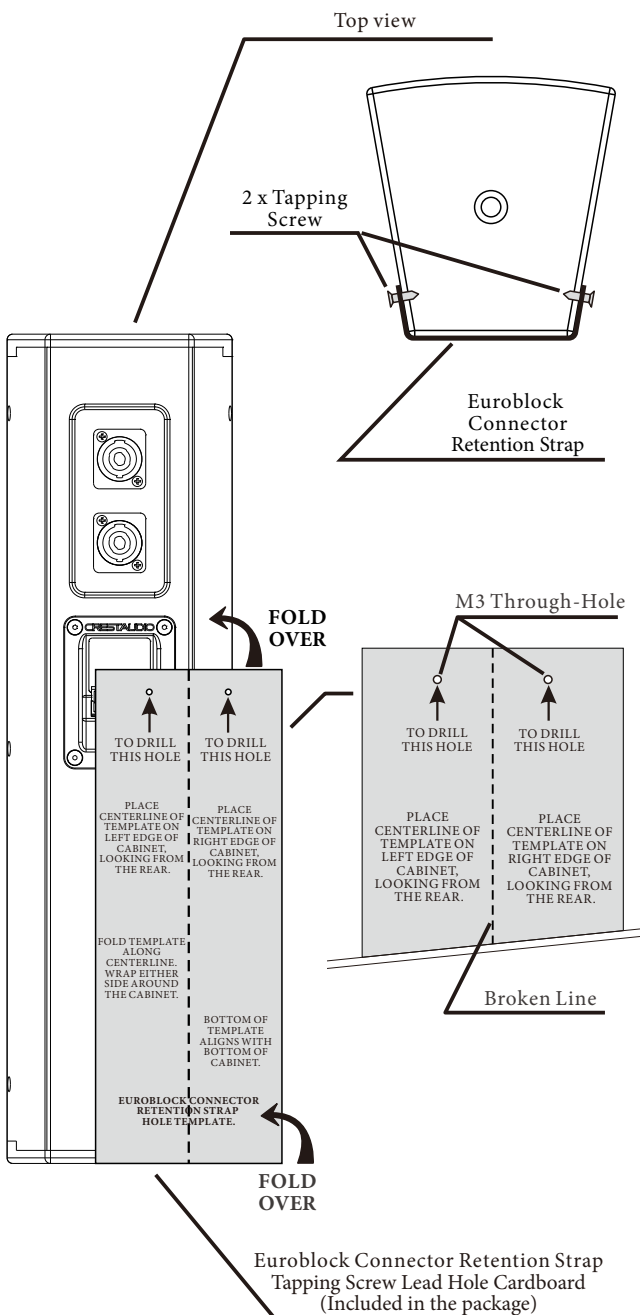
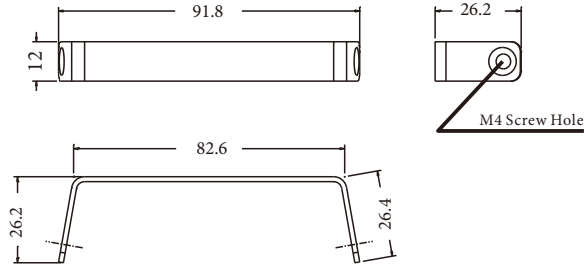

Euroblock Connector Retention Strap Tapping Screw Lead Hole Cardboard
(Included in the package)

Operation Process

Use the screw pilot hole of the retention strap to align the bottom of the cardboard with the speaker, and align the origami board to fit the cardboard with the back of the speaker and one side of the speaker.

Use a drill bit to turn through the M3 through-hole reserved in the cardboard. The drill bit is recommended to use the M2 specification, which should not exceed the M3 specification.

Repeat the above operation for the other side panel.

Place the Euroblock Connector Retention Strap against the speaker, align the M4 screw hole with the pilot hole of the side plates on both sides as far as possible, and fix it with M4 self tapping screws.



Note: The Euroblock Connector Retention Strap is an optional accessory. Once used, it will cause cosmetic damage to the speaker cabinet which can not be reversed. Please only apply when the Euroblock connector is used.

CPL+ Series Input & Loop Through Schematics

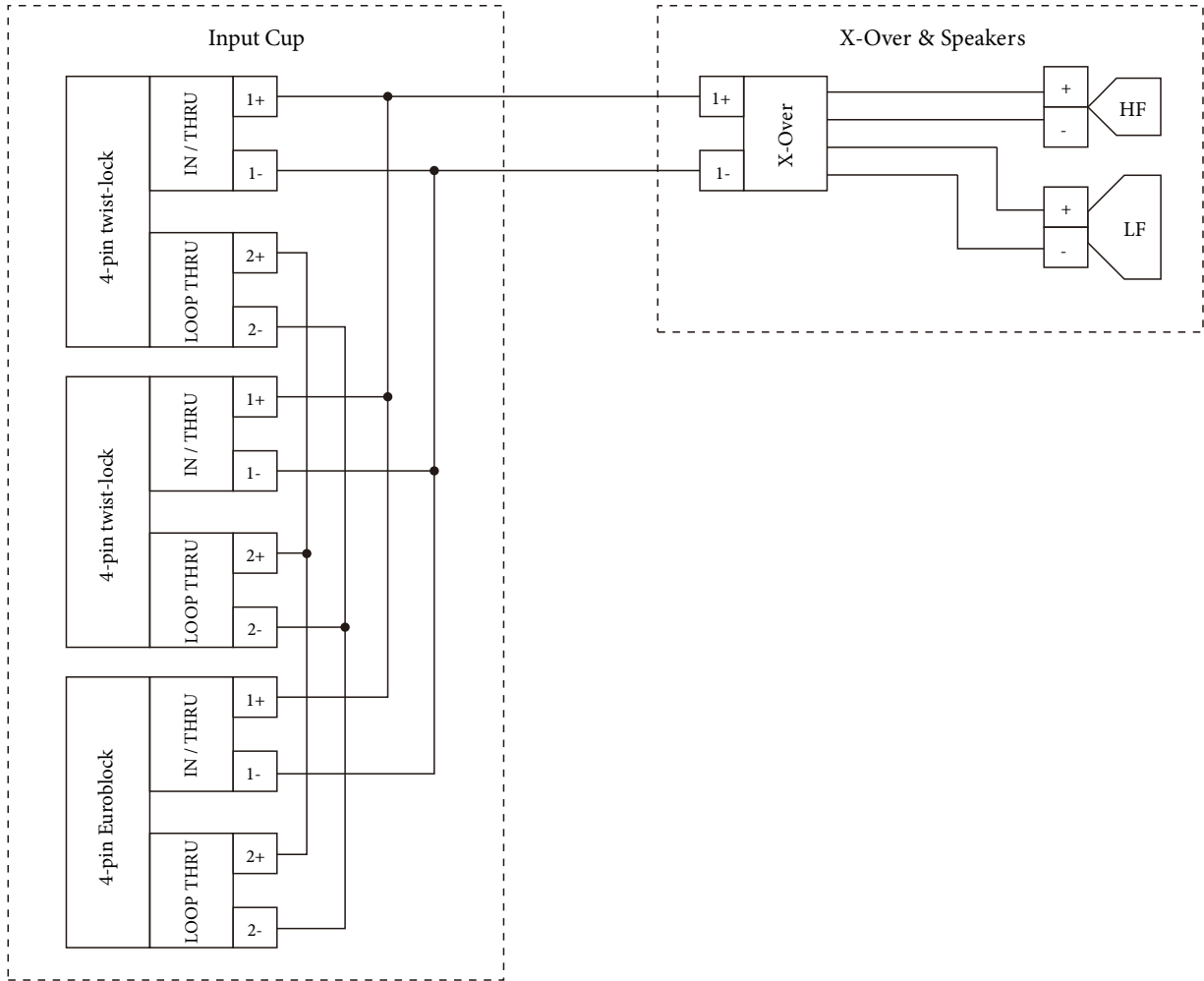

CPL+ Series Loop Through System Schematics

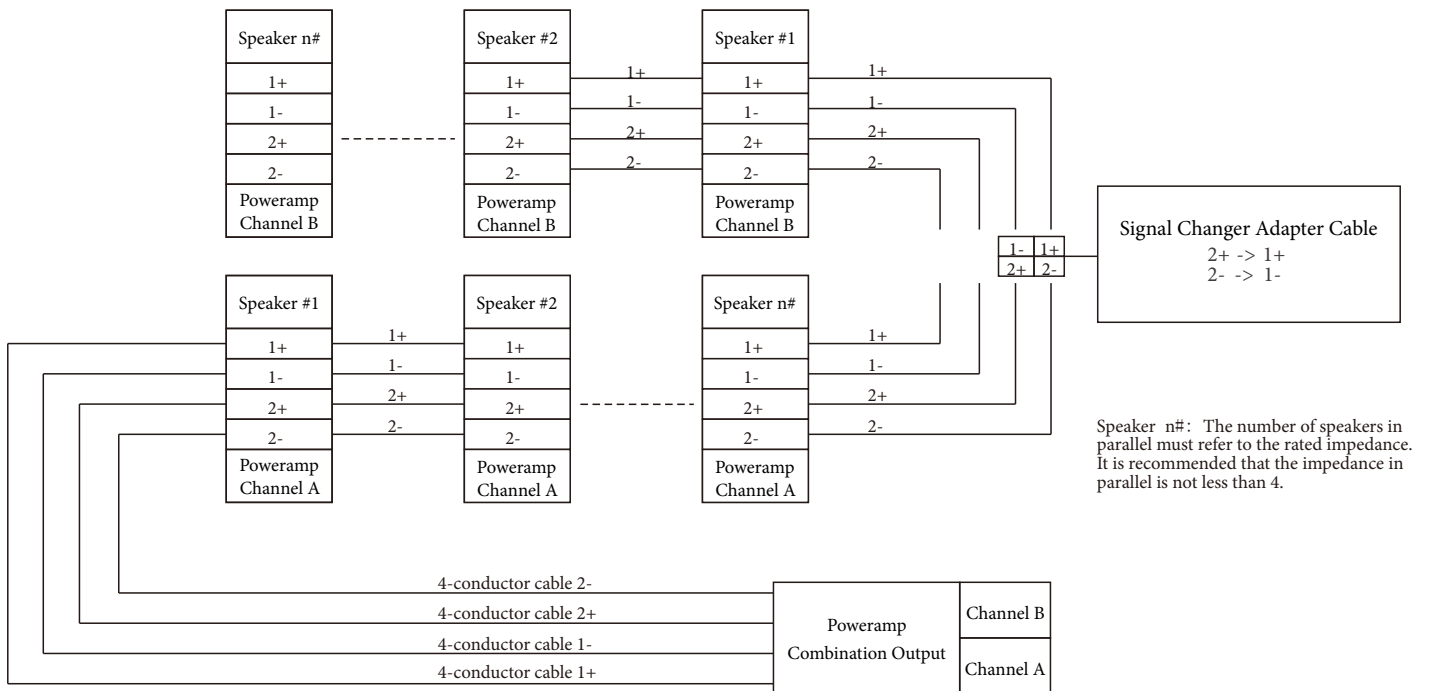

Unit: mm

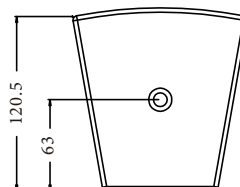
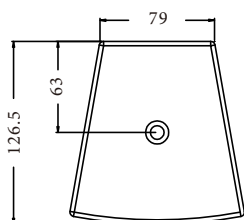
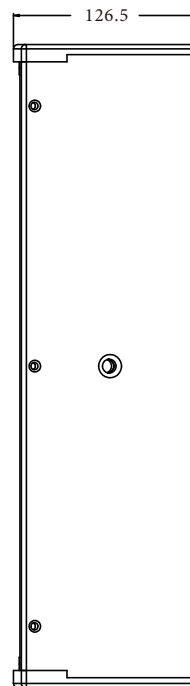
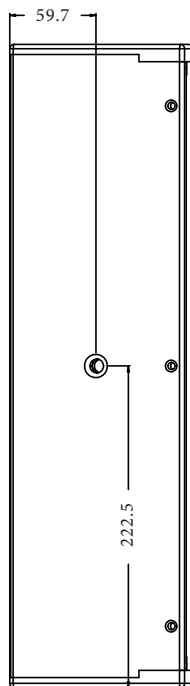
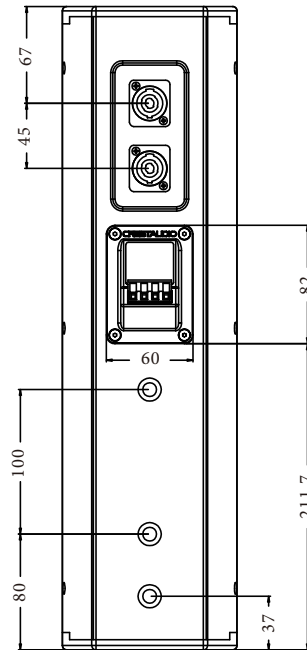
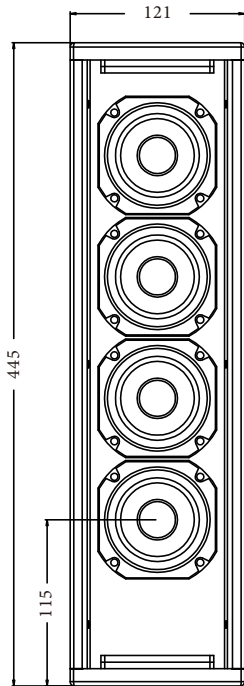

The compact passive column array loudspeaker shall consist of four 3 inch (76 mm) full-range Neodymium transducers with 0.75 inch (20 mm) voice coil.

Performance specifications of a typical production unit shall be: Measured sensitivity SPL at 1 m (3.3ft) with 2.83V input, shall be 93 dB-SPL. Usable frequency response shall extend from 150 Hz to 20 kHz (10 dB below rated sensitivity, in full space, with no external equalization). Nominal impedance shall be 8 Ohms. Rated power capacity shall be at least 120 Watts continuous power and 480 Watts peak power, defined as 6 dB above a test signal of filtered random noise.

The system shall be capable of even coverage at a nominal 90° horizontal through 25° vertical distributed pattern.

The enclosure shall be constructed from prime-grade 12 mm plywood. The loudspeaker shall be equipped with a total of thirteen (7) suspension points. The grille shall be of heavy-duty steel backed with acoustically transparent foam. The external wiring shall be via either two 4-pin twist-lock or one 4-pin Euroblock connectors. The loudspeaker shall be 17.52 inches (445 mm) high by 4.72 inches (121 mm) wide by 4.98 inches (126.5 mm) deep weighing 6 pounds (2.7 kg). The finish shall be a paintable lightly textured black or white.

The compact column array loudspeaker shall be the Crest Audio CPL 4L⁺.

Frequency Response

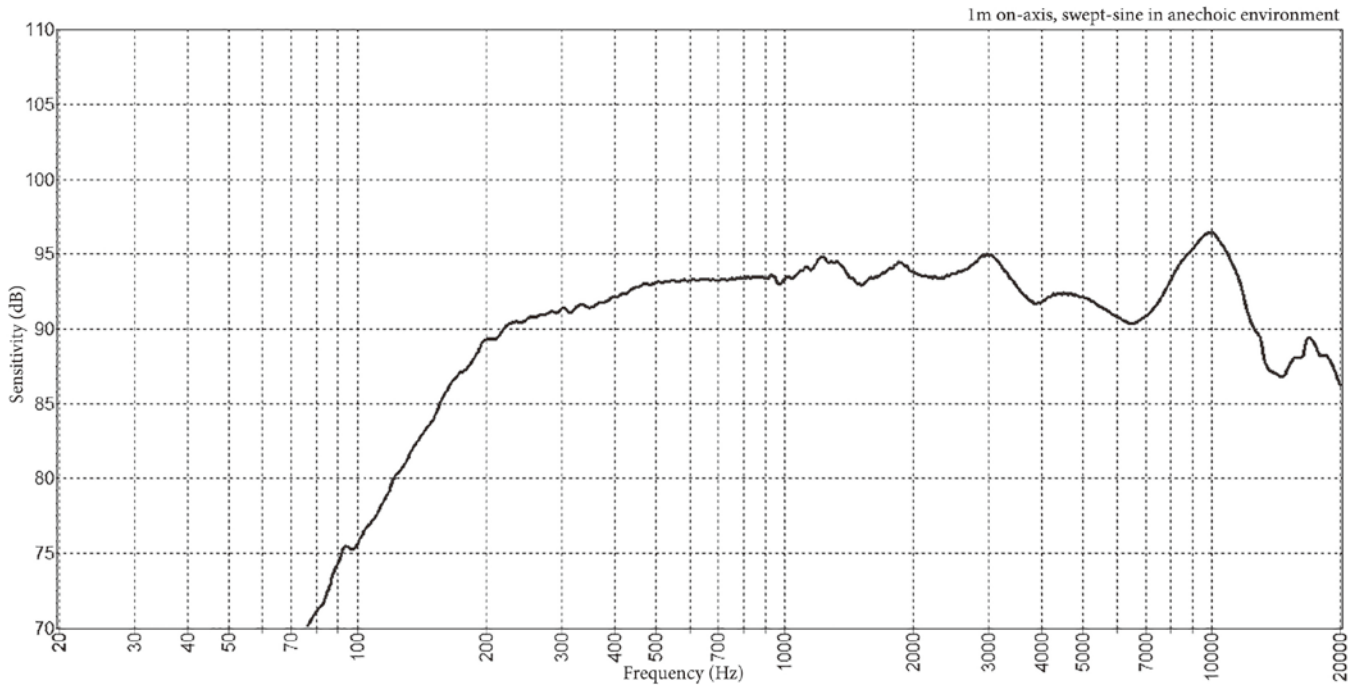

Impedance

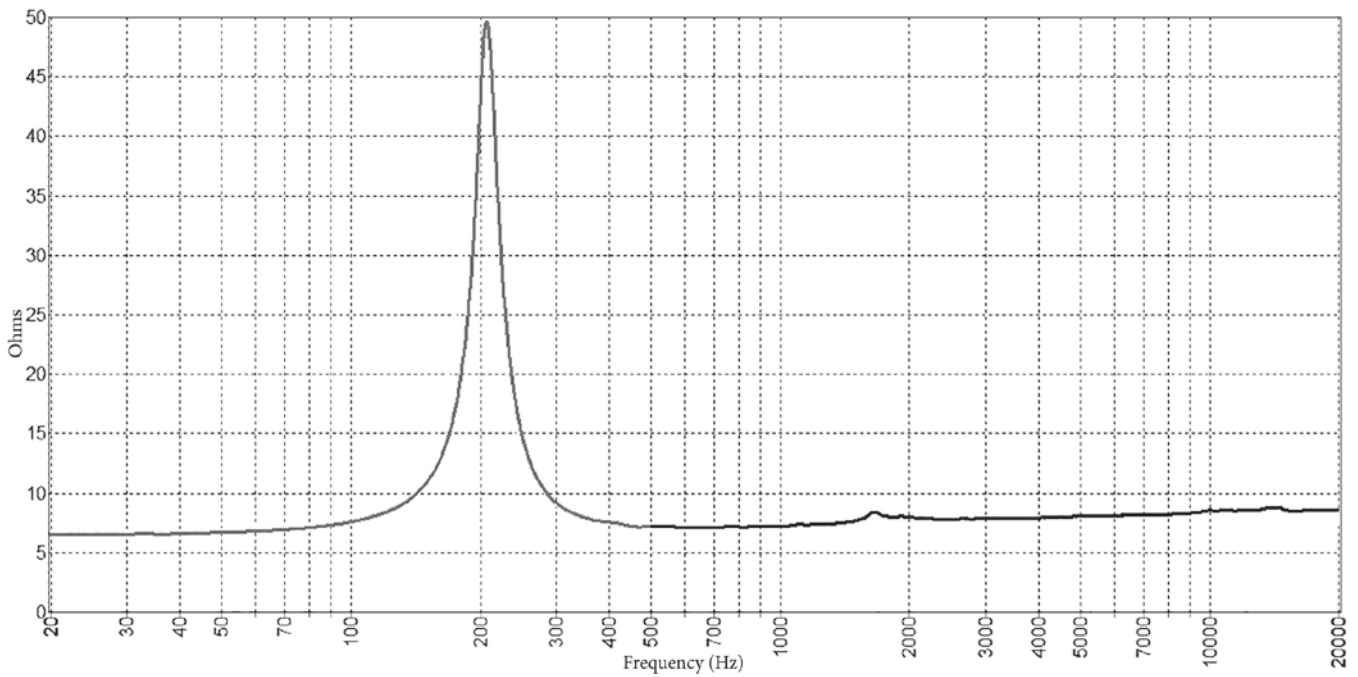



www.crestaudio.com



Features and specifications subject to change without notice.

Crest Audio 5022 HWY 493 N. Meridian, MS 39305 (601) 483-5365 FAX (601) 486-1278



Logo referenced in Directive 2002/96/EC Annex IV
(OJ(L)37/38,13.02.03 and defined in EN 50419: 2005
The bar is the symbol for marking of new waste and
is applied only to equipment manufactured after
13 August 2005