

## SPECIFICATIONS

## Studio Pro CM™ 1



**TYPE:**  
Back-electret condenser  
microphone

**ELEMENT:**  
Pressure gradient, transformer FET  
circuit

**POLAR PATTERN:**  
Cardioid (unidirectional)

**RATED OUTPUT IMPEDANCE:**  
200 Ohms

**RECOMMENDED LOAD IMPEDANCE:**  
1000 Ohms

**FREQUENCY RESPONSE:**  
50 Hz to 16 kHz

**SENSITIVITY:**  
-43 dBV/Pa (7.1 mV/Pa)

**SELF NOISE  
(EQUIVALENT SPL):**  
24 dB  
(A-weighted per IEC 651)

**MAXIMUM SPL:**  
136 dB at 1 kHz  
(THD < 1%)

**SIGNAL TO NOISE:**  
70 dB

**DYNAMIC RANGE:**  
112 dB

**POWER REQUIREMENTS:**  
48 Volts

**CURRENT CONSUMPTION:**  
3 mA

**CONNECTOR:**  
Three-pin XLR

**POLARITY:**  
Positive pressure on diaphragm  
produces positive voltage at pin 2  
relative to pin 3

**DIMENSIONS:**  
1.920" (48.77 mm) maximum body  
diameter, 7.140" (181.36 mm) long

**PACKAGING:**  
Compact carrying case

**NET WEIGHT:**  
.7 lbs. (317.5 g)

### FEATURES:

- High SPL durability, wide dynamic range
- Pressure gradient, transformer FET circuit
- Low handheld noise and double-layer POP filter
- Ideal as main and support microphone in live applications

### DESCRIPTION

The Studio Pro CM1 is a handheld condenser microphone with a cardioid pickup pattern and a medium format condenser element designed to handle SPL levels up to 136 dB while maintaining a clean natural sound. The CM1 has a sensitivity of -43 dBv per pascal and a low noise floor, equivalent to only 24 dB SPL. The shock mounting of the CM1 produces very little handling noise, making it ideal for vocals or instrumentals. The frequency response is tailored to give a crisp, clean, intelligible sound from 50 Hz to 16 kHz. The CM1 is equipped with a dual-layer pop filter to reduce pops and wind noise.

### 2 YEAR LIMITED WARRANTY

**NOTE:** For details, refer to the warranty statement. For copies of this statement, contact Peavey Electronics Corporation, at P.O. Box 2898, Meridian, Mississippi 39301-2898, or go online to [www.peavey.com](http://www.peavey.com).



# SPECIFICATIONS

# Studio Pro CM™ 1

## Pickup Patterns

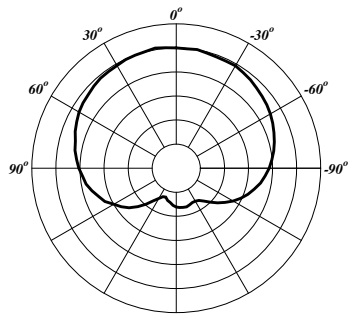

125 Hz

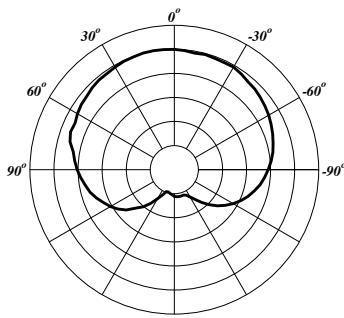

250 Hz

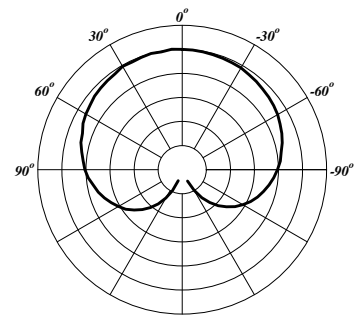

500 Hz

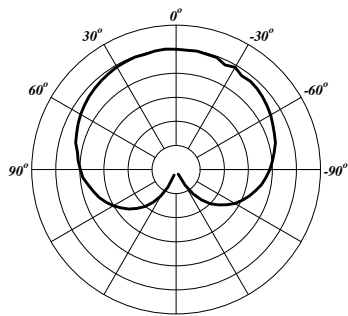

1 kHz

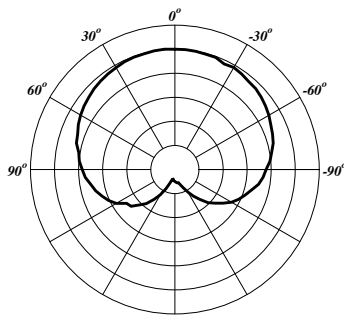

2.5 kHz

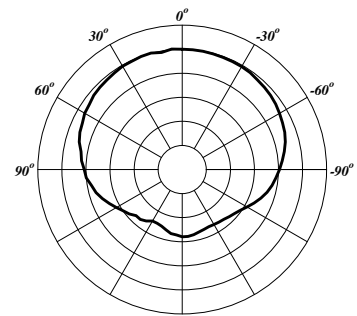

5 kHz

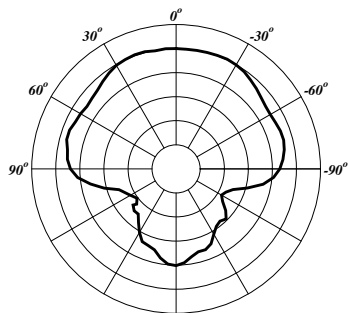

10 kHz

## Amplitude Response (Front & Rear)

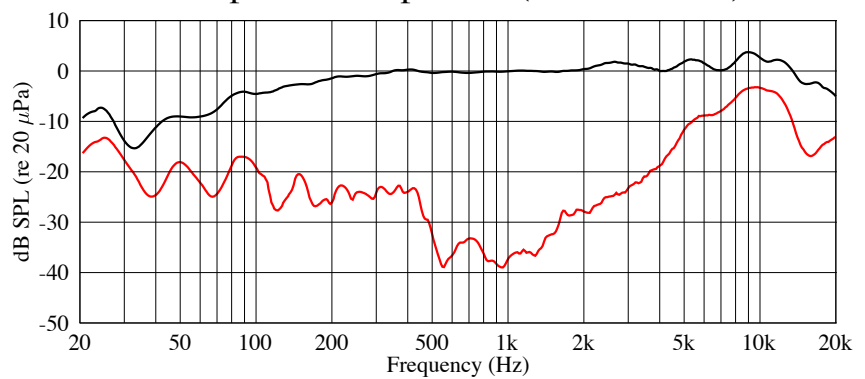

Features and specifications subject to change without notice.

Peavey Electronics Corporation • 5022 Hartley Peavey Drive • Meridian, MS 39305  
Phone: (601) 483-5365 • Fax: (601) 486-1278 • [www.peavey.com](http://www.peavey.com)

©2011 Printed in the U.S.A. 1/11 80307092

